

NOTE: FOR INTERIOR APPLICATIONS AND NON CORROSIVE ENVIRONMENTS, T-304 S.S. IS RECOMMENDED. FOR EXTERIOR APPLICATIONS WITHIN 15 MILES OF THE COAST OR IN A CORROSIVE ENVIRONMENT, T-316 S.S. IS RECOMMENDED.

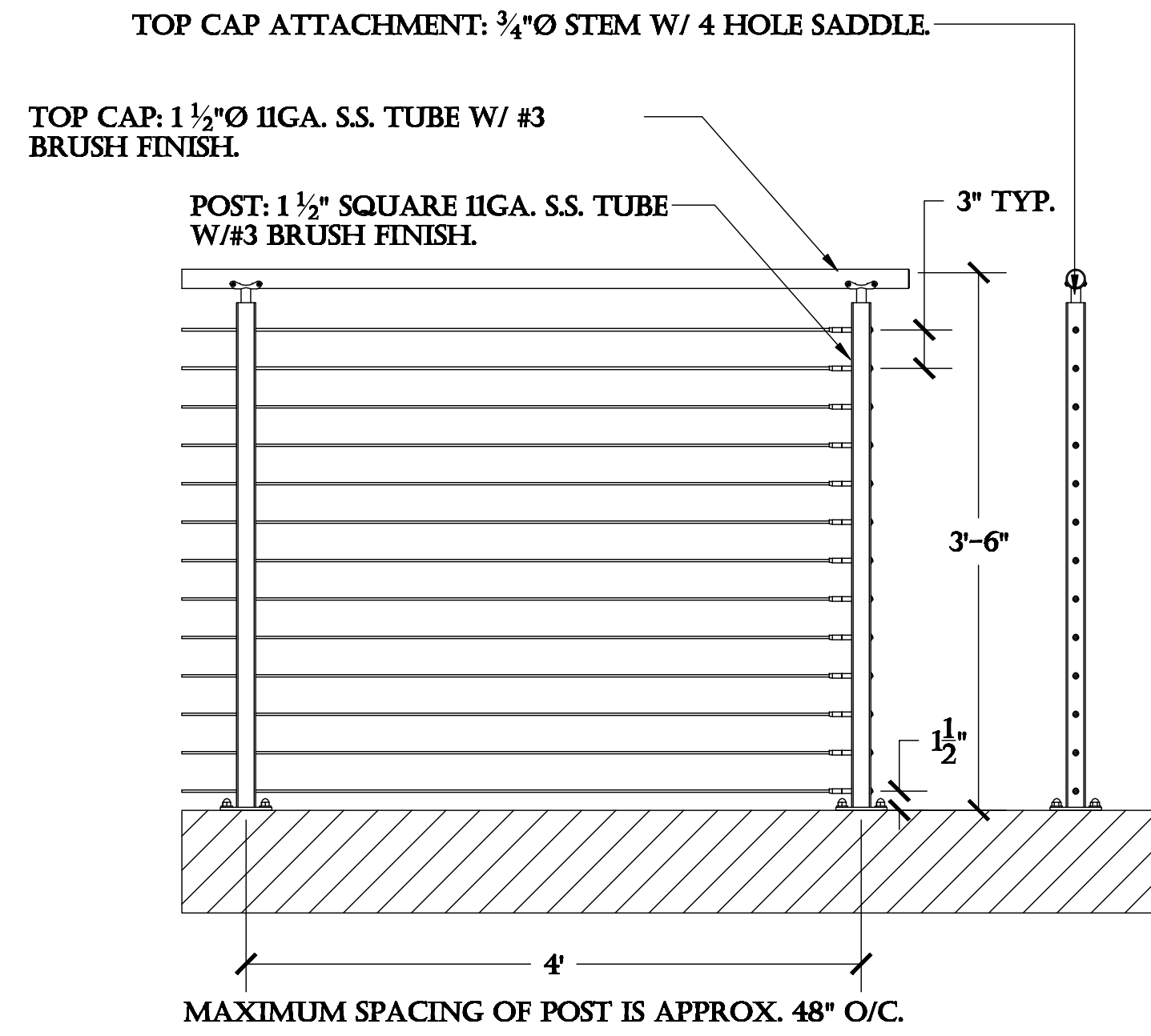

SPI-2000 LEVEL 42" GUARD RAILING.

SCALE: 1" = 1'

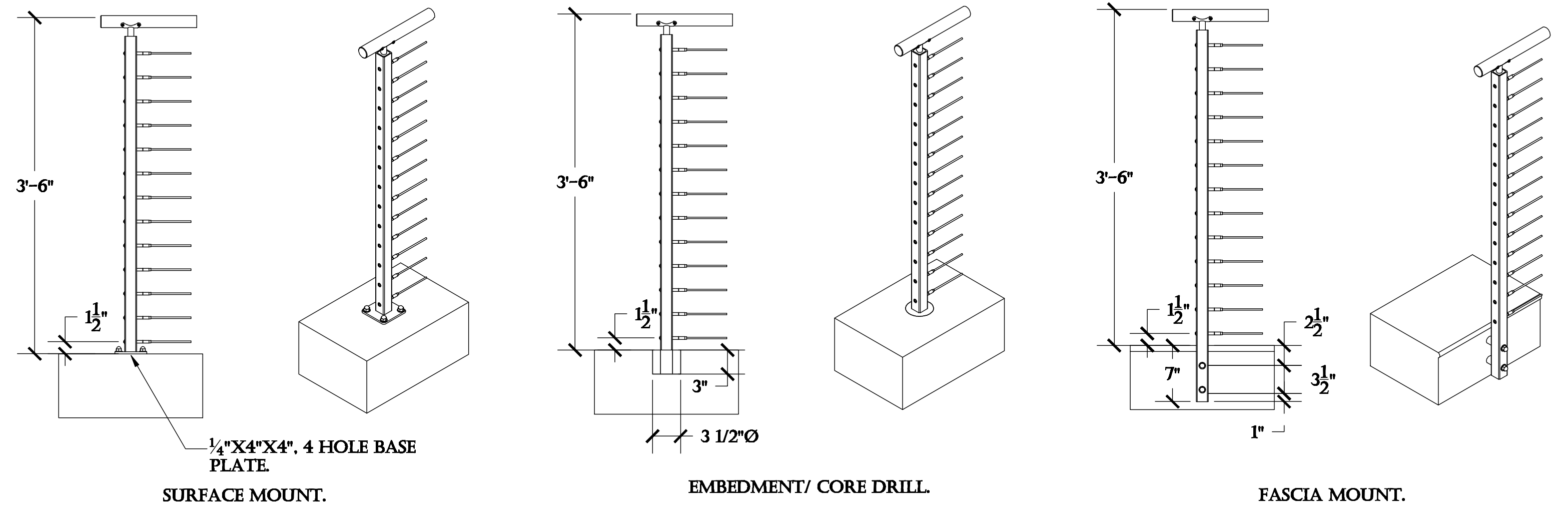

SPI-2000 TYPICAL MOUNTING OPTIONS.

SCALE: 1" = 1'

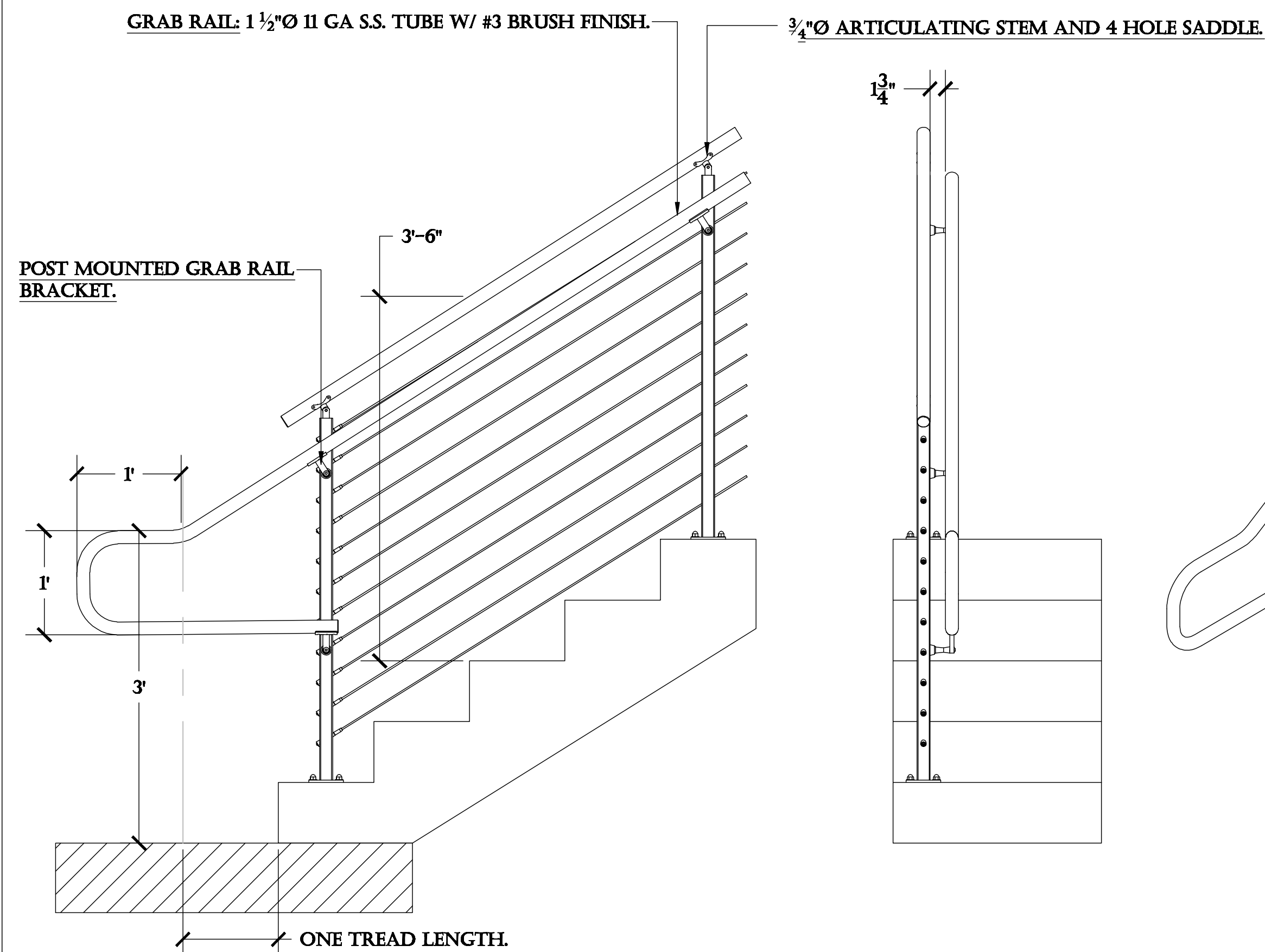

SPI-2000 42" STAIR GUARD RAILING.

SCALE: 1" = 1'

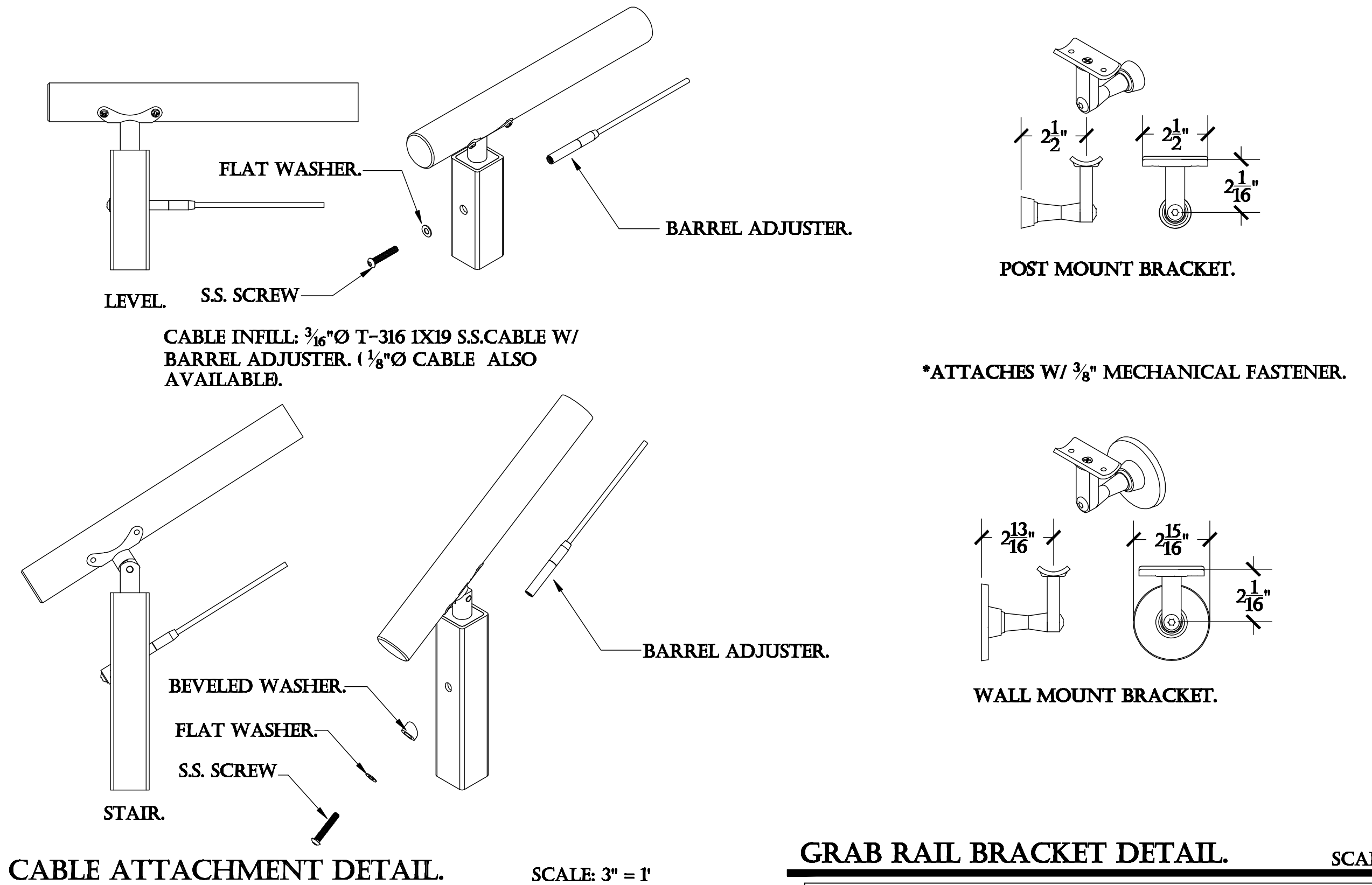

CABLE ATTACHMENT DETAIL.

SCALE: 3" = 1'

GRAB RAIL BRACKET DETAIL.

SCALE: 3" = 1'

PRODUCT:
SPI-2000 S.S. CABLE RAILING SYSTEM.
 CONTENT:
SPI-2000 STANDARD SYSTEM DETAILS.
 DRAWN BY: **KELLER, C.**
 DATE: **08-19-11**
 PROPRIETARY AND CONFIDENTIAL:
 THE INFORMATION CONTAINED IN THIS
 DRAWING IS THE SOLE PROPERTY OF
 SECO SOUTH INC. ANY
 REPRODUCTION IN PART OR AS A WHOLE
 WITHOUT THE WRITTEN PERMISSION OF
 SECO SOUTH INC. IS PROHIBITED.

2111 34TH WAY
 LARGO, FL 33771
 PH: 727-536-1924
 FAX: 727-539-6314
 SALES@SECOSOUTH.COM

